

# SPN Conference

## Conference Interface

TECHNICAL DATA



- **Advanced Acoustic Echo Cancellation**
- **Dual Codec interfaces**
- **Three Site Bridging**
- **Proportional Gain Auto Mixing (PGA™)**
- **Third Octave Noise Filter on each channel**
- **TCP/IP Ethernet Addressable**
- **Power Amplifier Outputs**

The power and flexibility of the ASPEN family extends into the world of telepresence and audio conferencing with the SPN Conference interface. The SPN Conference is used with an ASPEN mixer to combine far end audio with a local sound system and integrate the signals into the ASPEN matrix.

The far end audio signals participate in the same manner as local microphones connected to the mixer. Two Codecs and a telephone line can be bridged into a single conference as seamlessly as local microphones. Multiple units can be used to add additional sites to a conference.

The ASPEN AEC (acoustic echo canceller) that is included was developed to address the growing need for a single acoustic echo canceller that could handle the challenges of multi-site bridging and an unlimited number of microphones. The AEC converges very quickly, then continues to increase the cancellation depth as a conference continues. Cancellation depth will increase even with brief signal peaks from the far end, and convergence will never be lost with any type of signal or even in double talk situations.

The AEC in combination with the patented gain proportional mixing algorithm\* provides outstanding audio quality without echo heard at the far ends.

*\*US Patents 5,414,776 and 5,402,500*

Signals from the far ends of the conference are routed the local sound system and also to a final mix that is used as a reference signal by the AEC. Audio from the local microphones (which includes far end audio from the local loudspeakers) is routed to the AEC via a second final mix for cancellation of the far end signals. After processing, the output of the AEC is routed back to the far ends through the matrix.

The proprietary noise reduction filter used in ASPEN mixers is also available in this conference interface. It is very effective when applied to the far end Codec and telephone line signals when poor connections occur.

A two channel power amplifier is included for loudspeakers in the local sound system. The power amplifier is driven by final mix outputs from the matrix and has a full set of signal processing, including delay, parametric EQ, compressor and limiter. Class-D amplification is implemented with a late generation component that provides exceptional efficiency, low heat, excellent audio performance and cannot be damaged by wiring errors.



## Signal Flow

Two Codec interfaces and a telephone line are processed and delivered to the ASPEN matrix in the same manner as microphones are handled in an ASPEN mixer. Four additional *Virtual* inputs receive signals from a built-in signal generator, which is used for testing and diagnostics.

The AEC receives signals from two final mixes that supply far end and local audio signals needed for echo cancellation. The AEC output after cancellation is then routed through the matrix to the appropriate Codec and telephone line outputs.

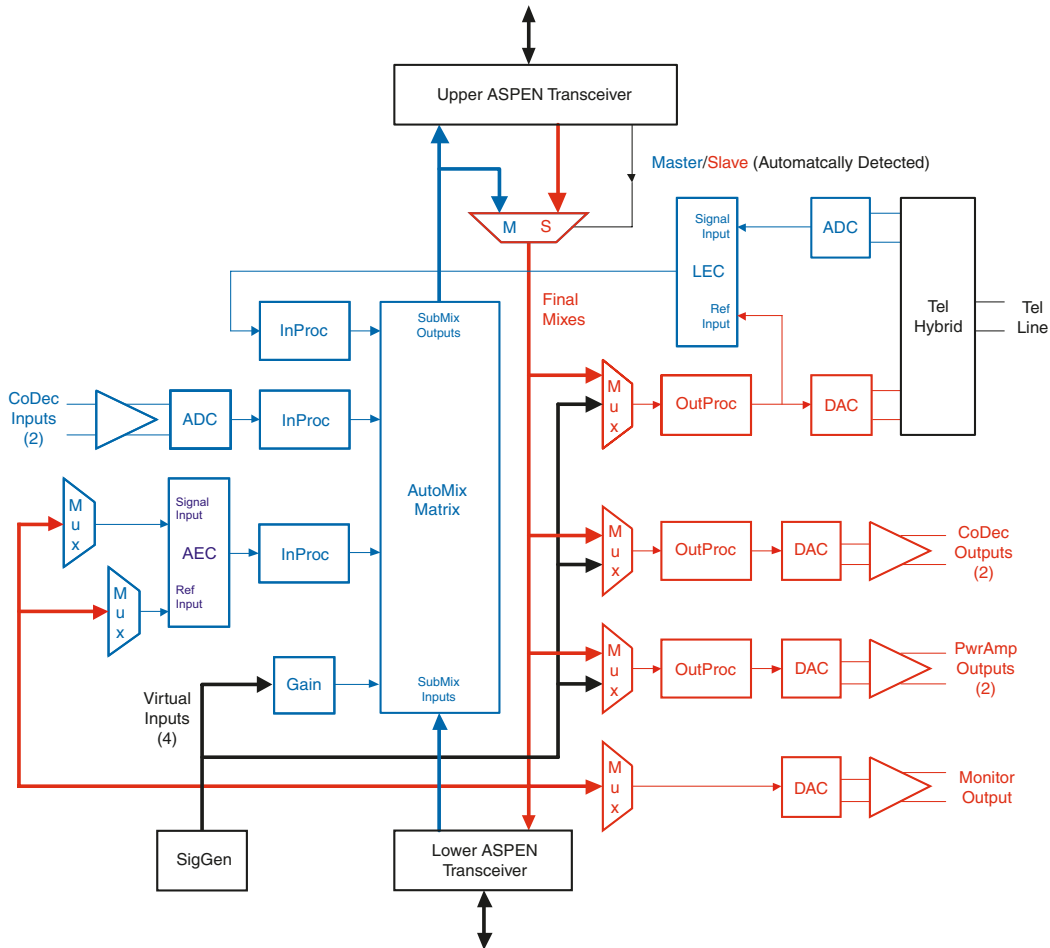

## Power Amp Outputs

The amplifier is designed to run continuously (idle or with a load) without heat buildup, making it ideal for permanent installations where prolonged operation is required.

Each output can drive a variety of loads, including loudspeakers, long cable runs and headphones. The BTL (bridge tied load) configuration allows the two channels to be wired in parallel on a common load to double the output power.

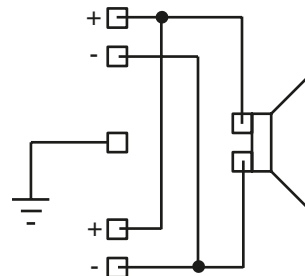

BTL output wiring

## Advanced Acoustic Echo Cancellation

Conventional AEC algorithms face a trade-off between convergence rate and depth. A fast convergence time adapts quickly when a new conversation begins or when a change occurs in the acoustic space, but the cancellation depth is limited. Deeper cancellation requires more time, so an echo may be heard at the far end until the AEC achieves a fairly deep convergence.

An ideal AEC would react very quickly in the beginning and then start applying more calculations over longer time intervals to achieve a deeper cancellation as the conference progresses. It would also maintain convergence regardless of signal types or levels. This is precisely what the ASPEN echo canceller does. It is designed to handle multi-site bridging and any number of microphones simultaneously, and it works with the gain proportional mixing algorithm perfectly.

The example shown here is an 11 second time period with far end audio activity only for the first few seconds, followed by near end audio overlapping the far end. This is only one example. The AEC convergence rate and depth will vary with different near and far end audio activity.

The uppermost plot shows the audio signal from the far end of the conference as it began. In an ASPEN system, this could be a mix of up to three far end sites connected to a single SPNConference interface.

The second plot shows the signals from local voice activity in the microphones, with the audio beginning a little under 7 seconds into the conversation.

The third plot shows the audio that entered the local microphones, which is a combination of far end audio from the loudspeakers, plus local voice signals and noise. During the time period between about 7 and 11 seconds, the local voice signal overlaps the far end audio signal to create what is known as *Double Talk*, which is a challenge for the AEC to maintain convergence.

The lowermost plot shows the ERLE that the ASPEN AEC achieved during this time period:

- Very fast convergence to 25 dB in depth in the first second of the conference
- Continued increases in depth until 6 seconds into the conference
- Maintained convergence during *Double Talk* from 7 seconds through the end of the recording

Look closely at the peak in the far end audio that occurred at just under 6 seconds; the largest peak in the time period. Then notice the increase in the ERLE plot when this audio peak occurred. The AEC took the opportunity to increase the cancellation depth with even this brief peak in the far end audio signal.

The AEC will not diverge (lose convergence) unless something changes in the local acoustic environment, such as a microphone moving. When this happens, it will converge again and adapt to the new echo path. These are usually very subtle changes and go completely unnoticed by the conference participants.

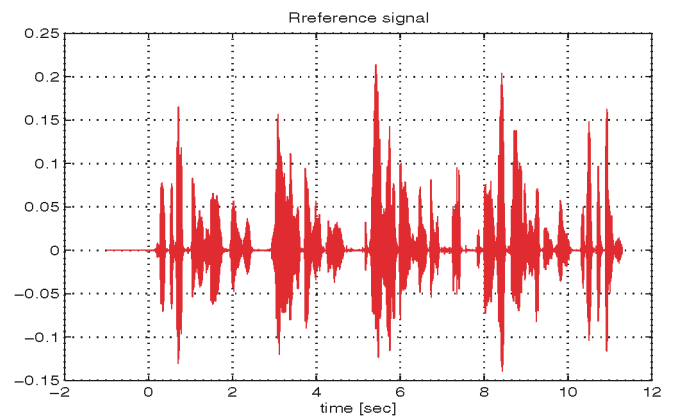

Far end audio

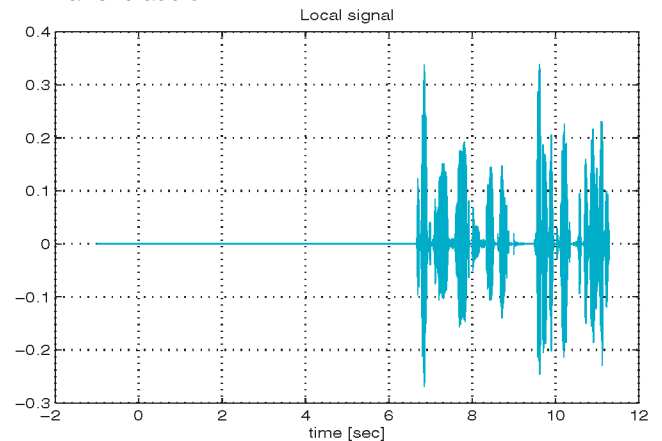

Local voice activity

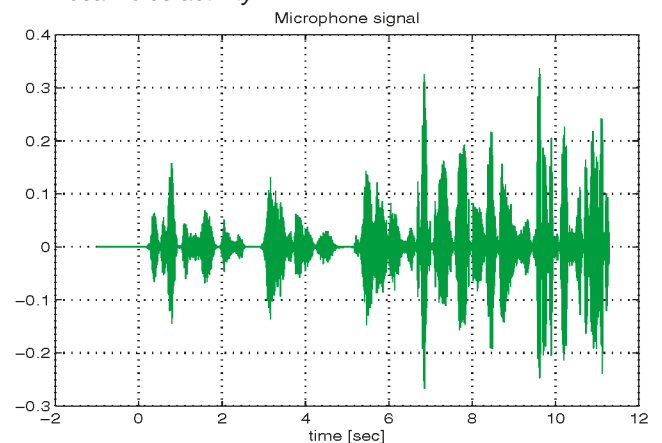

Audio entering the local microphones

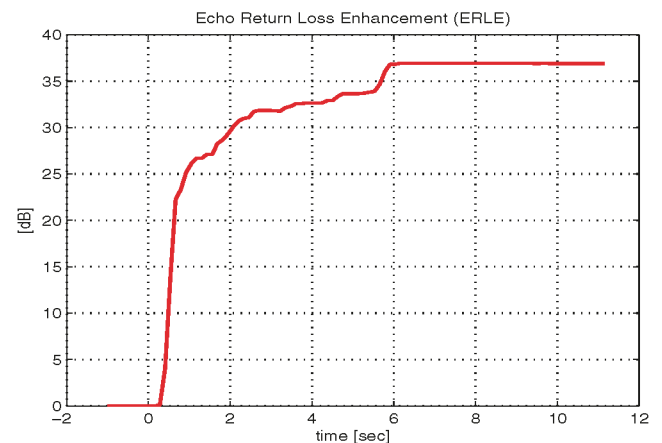

ERLE and convergence time

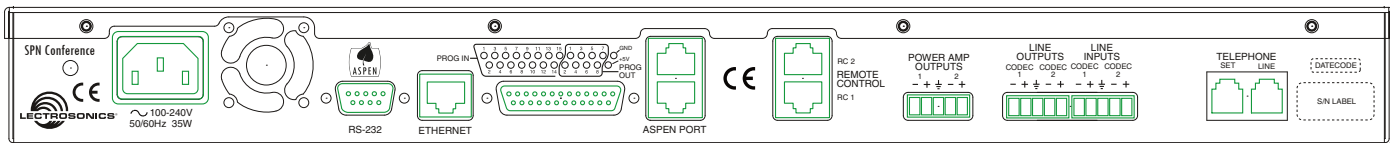

## Specifications

**Acoustic Echo Canceller:** 128 ms tail time - will never diverge, regardless of signal type (e.g. sine wave)

**Line Echo Canceller:** 48 ms tail time

**Telephone Hybrid Return Loss:** 26 dB + line echo canceller = 45 dB

**Audio inputs (Codec):**

Gain: -20 dB to +20 dB, programmable in 1 dB steps  
 Input impedance: 15k ohm (differential); 375k (common)  
 Connector: 5-pin Phoenix

**Audio outputs (Codec):**

Nominal level: Floating balanced  
 0 dBu  
 Output impedance: 50 Ω

**Input Dynamic Range (Codec):** 102 dB (unweighted 20 - 20 kHz)

**Output Dynamic Range (Codec):** 105 dB (unweighted 20 - 20 kHz)

**Audio THD + noise (Codec):** 0.01%

**Front Panel Connectors:**

- 1/4 inch headphone monitor jack with level control
- Standard USB Type B receptacle

**Rear Panel Connectors:**

Power: IEC 60320 C14  
 RS-232: DB-9  
 Ethernet: RJ-45  
 Programmable Logic I/O: DB-25  
 ASPEN port: Dual RJ-45  
 Remote control: Dual RJ-45  
 Power amp output: 5-pin Phoenix  
 Line Inputs/Outputs: (2) 5-pin Phoenix  
 Telephone Set/Line: (2) RJ-11

**Proprietary network:**

Physical level: LVDS (Low Voltage Differential Signal) high speed  
 Cable type: CAT-6  
 Transmission speed: 1 Gbps

**Programmable control inputs:**

Number of inputs: 15  
 Analog voltage range: 0-5V  
 Logic input: TTL, LVTTTL, CMOS, LVCMOS

**Programmable control outputs:**

Number of logic outputs: 8  
 Logic control: active low  
 Max sink current: 100 mA  
 Max supply voltage: 40 V  
 Supply voltage for control I/O: 5 V  
 Max current: 750 mA

**Cabled Remote Controls:**

Codec 1: Lectrosonics RCWTH4; RJ-45 jack  
 Tel: Lectrosonics RCWTH4; RJ-45 jack

**Power requirements:**

100-240 VAC, 50/60 Hz

**Power consumption:**

15 Watts

**Dimensions:**

Faceplate: Standard 19 x 1.75 inch 1RU  
 Housing (WxHxD): 17.50 x 1.72 x 7.25 inches

**Weight:**

3.56 lbs. (without AC cord)

