

DNT 16i

TECHNICAL DATA

Network Processor



- 16 mic/line analog inputs with 48V phantom power and wide range gain control
- 16 Dante™ digital inputs
- 32 Dante™ digital outputs
- Supports both switched and redundant modes in Dante™ operation
- Pre-mixing signal processing on all 32 inputs (analog and digital)
- 48 independent automatic mixers with 36 inputs per mixer and channel activity detectors
- Support for multi-level mixing: mixes can be looped back and used as mixer inputs
- Extensive signal processing including filters, delay and channel linking for dynamic processing (compressors, limiters)
- Gain smoothing to prevent transient noise during instantaneous level changes
- Four test signal generators available for system setup and testing
- Extensive macro command language
- Control interfaces via USB, RS-232, Ethernet and programmable logic I/O
- Rack mount or under table mount



Dante™ is a trademark of Audinate Pty Ltd.



Rio Rancho, NM, USA
www.lectrosonics.com

Introduction

DNT Series processors operate as native Dante™ devices to integrate analog and digital network signals in a seamless manner. Analog audio signals are converted to digital signals that are then processed and assigned to Dante network channels. Digital signals from the Dante network are processed in the same manner as analog signals, then sent back into the Dante network or converted to analog for mic/line outputs. The result is seamless integration of analog and digital audio signals into a common network where any signal assigned to a Dante transmit channel is then available at any receiving device connected to the network.

The hardware can be located in a single rack or in separate locations, whichever better suits the needs of a particular installation. The network interconnection handles all signal flow and communication between the processors, so the distance between processors or racks is limited only by the cabling in use.

The DNT16i processor provides inputs into a Dante network from analog and digital signals. Each input provides extensive signal processing and routing to any one or all of 48 automatic mixers operating at the crosspoints of an internal digital matrix in the processor. The outputs of the matrix can be assigned to a Dante transmit channel and/or routed back to an input to be further mixed with another input or matrix mix.

The DNT16i is at home in sound reinforcement and conference systems, room combining, courtrooms, council chambers, house of worship systems and numerous other multi-channel sound systems. High quality microphone preamps and A-D converters provide studio quality audio for court recording and telepresence systems. A comprehensive set of filters and dynamic processing is present on every input channel. Smooth gain transition is enabled on every input and output channel, and every crosspoint, to prevent audible artifacts caused by abrupt level changes.

Signal routing options are extremely flexible. Each input can select signals from the Dante network, external analog sources, output mixes from the internal matrix and the internal signal generators. Each of the 48 automatic mixers in the internal matrix crosspoints can mix signals from any or all of the 32 input channels and the four signal generators.

All signal processing blocks on all inputs are enabled at all times. Changes made to filter values or signal routing take effect immediately.



The built-in Ethernet switch allows operation with either port in the **Switched** mode with a single network, and as primary and secondary ports in the **Redundant** mode with two networks.

Technology Overview

Dante delivers a no hassle, self configuring, true plug-and-play digital audio network that uses standard Internet Protocols over Gigabit Ethernet. Patent-pending Dante technology distributes digital audio plus integrated control data with sub millisecond latency, sample-accurate playback synchronization, extreme reliability and high channel counts.

NOTE: The Dante interface will also operate over 100 Mbps connections for some applications, however, this is not sufficient bandwidth for DNT processors due to the high channel count, so gigabit connections are required.

Plug-and-Play Networking for Media Professionals

Dante-enabled devices find each other on the network and configure themselves, so you can skip complicated, error-prone set-up procedures. Instead of “magic numbers,” you label networked devices and their input and output signals with names that make sense to you.

IP Standards Based Technology

Dante is built on global networking standards including Internet Protocols — not just Ethernet. With true IP routing, Dante technology works as an IT network capable of transporting professional quality audio and high definition video with no limits on your layout options. Dante delivers sample-accurate playback synchronization, even over multiple switch hops. Latency is extremely low whether you choose to run your Dante network with fixed latency or optimized latency. Dante makes it easy to set up robust, flexible digital audio networks with performance that scales with your network.

Media Networking over Existing Infrastructure and Hardware

Dante runs on inexpensive off-the-shelf computer networking hardware, and does not require dedicated network infrastructure. Ethernet switches transmit Dante digital media streams alongside ordinary data traffic, so you can integrate professional media operations into properly designed pre-existing networks. And with Dante Virtual Soundcard (DVS), your Mac or Windows computer looks and acts like any other Dante-enabled device. Just plug in to the standard Ethernet port to use digital audio processing, recording or playback software on the network.

Sample Accurate Timing with Inaudibly Low Latency

Dante uses audio independent, high accuracy network synchronization standards to ensure all Dante devices are synchronized at all times. Sample accurate playback with extremely low latency and jitter is achieved without limiting audio sample rates and network layout options.

48 Automatic Mixers, 36 Inputs Each

Automatic mixing takes place at the crosspoints in the internal matrix. The most obvious benefit is that each input signal can exhibit a different behavior at each of the output mixes. This means, for example, that input 1 can deliver a direct signal at one or more outputs, and participate in automatic mixing at other outputs.

A total of 48 automatic mixers are present. Each automatic mixer has 36 inputs:

- 16 from the analog preamps
- 16 from the Dante interface
- 4 from the internal signal generators

The internal digital matrix provides 48 different mixes, with each one having all 36 signal sources selectable as the input. Each input can participate in the mixing in one of the following manners:

- Automatic - normal auto mix activity
- Direct - on at all times; for recording
- Override - dominant in the mixing activity
- Background - subordinate in the mixing activity
- Phantom - for multi-zone mix-minus systems

This enables one input to have a different character in the mix at each output.

Real-time Connection

Changes to the settings in the processor are enabled instantaneously. There is no compiling, and the effect of the changes are heard immediately. This makes it easy to make fine adjustments by simply listening.

Control and Network Interconnections

The Dante signal transport and ethernet control can share a common network. USB, RS-232, logic I/O and the network interface operate simultaneously.

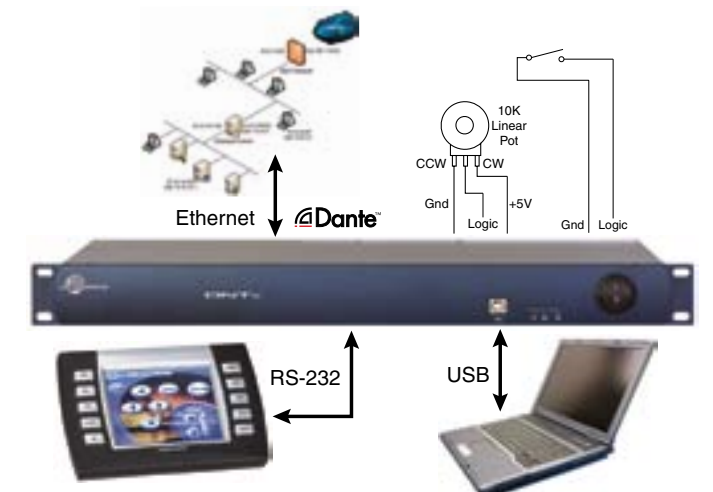

Dante Network Overview

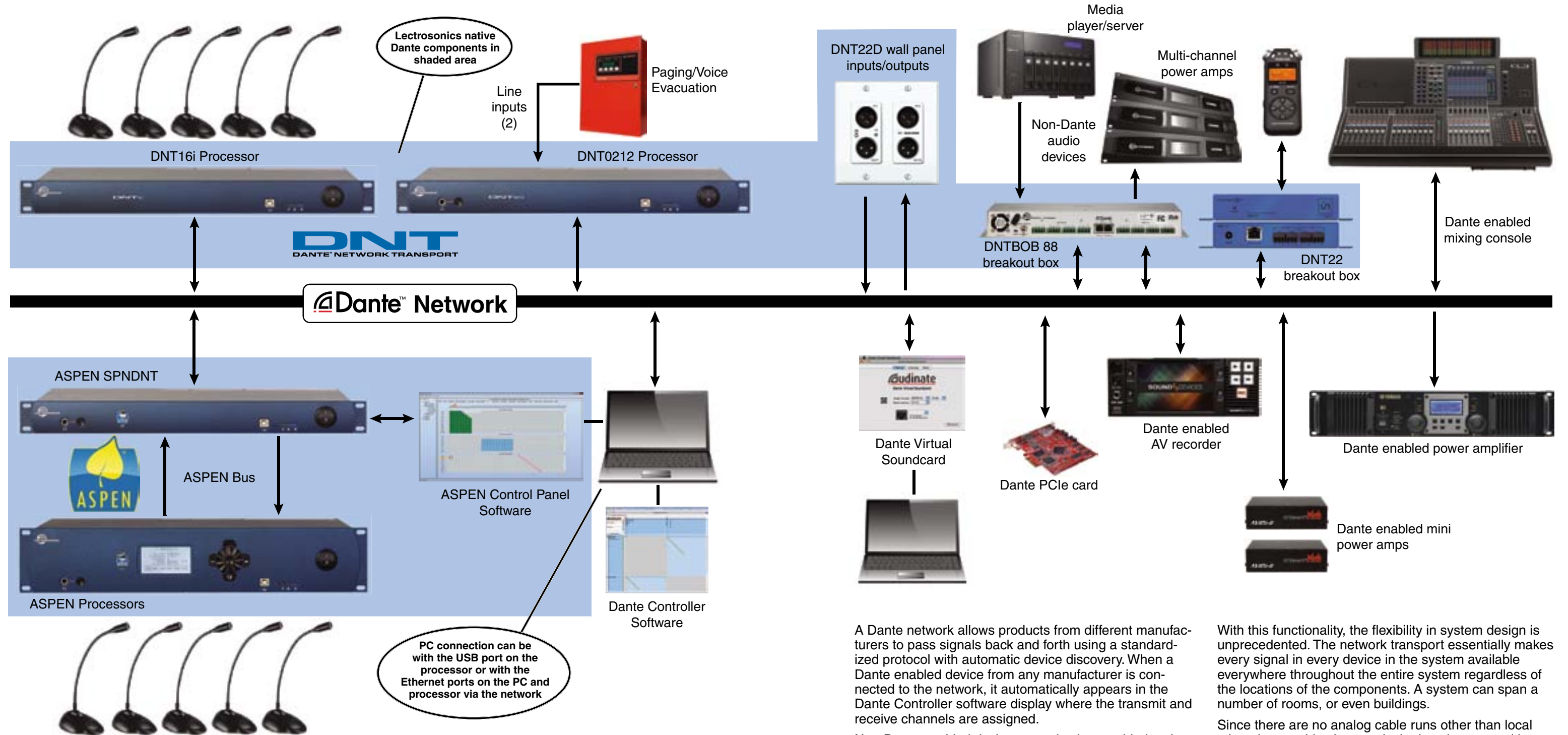

A Dante network provides an extremely simple interconnection and configuration of an increasingly wide variety of equipment from a growing list of manufacturers.

Lectrosonics DNT Series processors are native Dante devices that connect directly to the network to transmit and subscribe to signals on the network. Analog inputs and outputs are processed and routed in the same manner as the digital channels on the network.

Lectrosonics ASPEN Series processors interconnect with one another via a local bus. The SPNDNT processor is a native Dante device that operates as the Master unit in the ASPEN system to send and receive audio channels between the network and the local processors.

A Dante network allows products from different manufacturers to pass signals back and forth using a standardized protocol with automatic device discovery. When a Dante enabled device from any manufacturer is connected to the network, it automatically appears in the Dante Controller software display where the transmit and receive channels are assigned.

Non-Dante enabled devices can also be added to the network using the DNTBOB 88, DNT22D and DNT22 breakout boxes.

With this functionality, the flexibility in system design is unprecedented. The network transport essentially makes every signal in every device in the system available everywhere throughout the entire system regardless of the locations of the components. A system can span a number of rooms, or even buildings.

Since there are no analog cable runs other than local microphone cables in a particular location, ground loops are eliminated.

Signal Flow

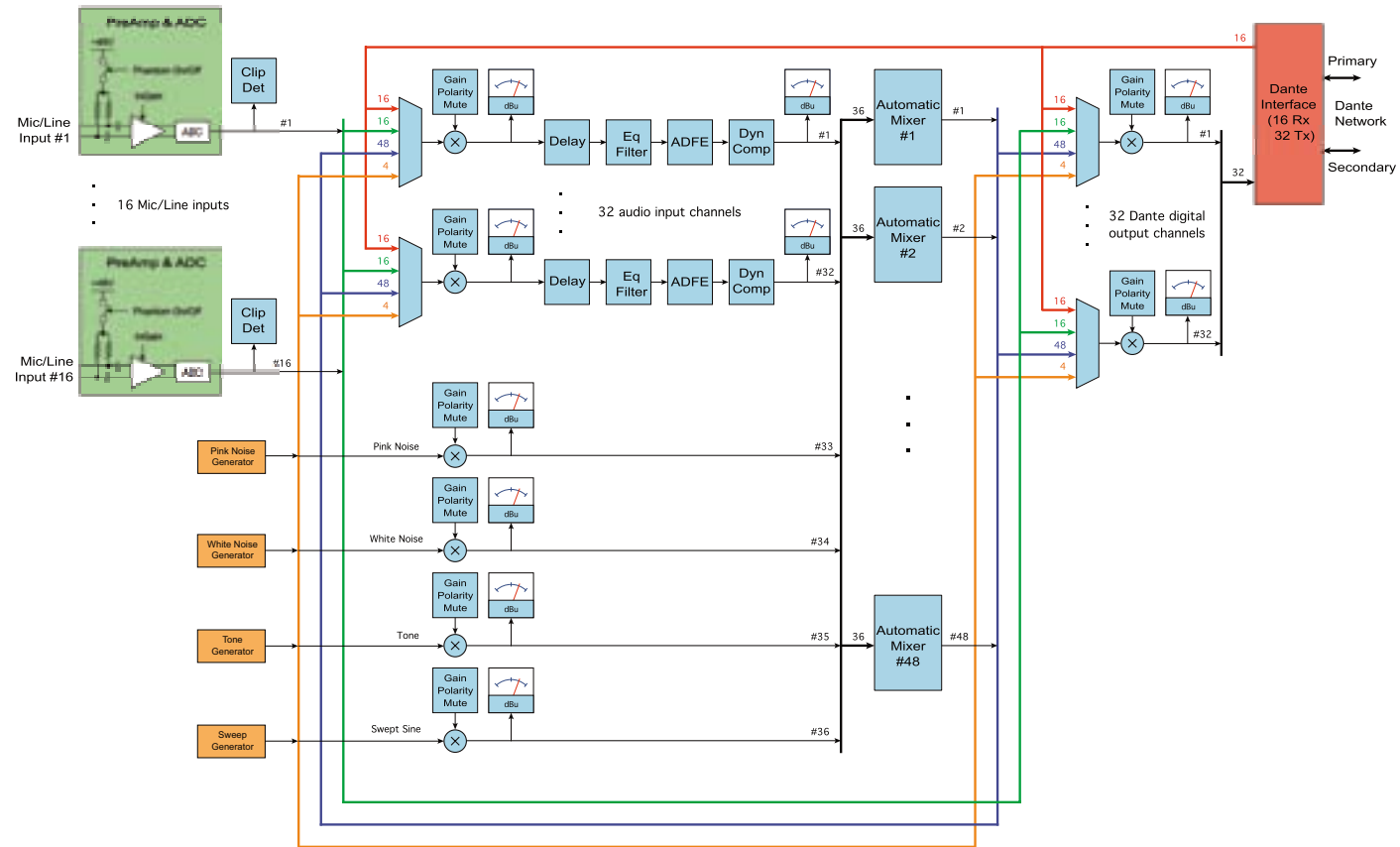

Signal Flow

Flexibility is at the core of the signal flow architecture. The multiplexers provide a rich routing resource that allows every audio signal present in the processor to be available at every input to the internal matrix mixer, every Dante transmit channel, and at every post mixing signal processing chain that feeds the analog outputs.

Inputs

16 analog inputs are digitized with high quality A-D converters and made available as inputs to the Dante interface and to the internal matrix. Each input to the matrix includes a comprehensive signal processing chain with a variety of filters, ADFE feedback eliminators and dynamic processing.

16 receive channels from the Dante matrix are available as digital inputs to the processor. Filters and dynamic processing for these digital inputs are the same as for the analog inputs.

Input Multiplexers

The input multiplexers select the input signal driving each of the 36 input channels. Any of the 16 mic/line inputs, the 16 Dante receive channels or the 48 matrix mixes may be selected.

Loop Back Paths

The bus structure provides a direct signal path from the output of the internal matrix back to the inputs via the input multiplexer. This allows multi-level mixing where a mix can be combined with other mixes or inputs, or an output can be routed back to another input to the mixer for further signal processing.

There is also a direct path available to route signals coming from the Dante interface directly back to the interface as a transmit signal, bypassing the processor signal processing. This allows the processor to route Dante channels with the least possible latency.

Filters and Dynamic Processing

Each input (digital and analog) includes a comprehensive signal processing chain, including:

- Delay: 0.1ms increments, 1 second max.
- 4 filter stages (see specs)
- 8 notch filters (ADFE), static and dynamic
- Compressor with RMS detector and linking of adjacent channels

All processing stages are fully enabled at all times. There is no “gas gauge” (resource meter) nor compiling to do because it is not necessary. If a filter value is not defined, it is essentially out of the processing chain.

Lectrosonics DNT Software

This software is used to set up the DNT processors. Screens presented in the GUI are re-sizeable. Signal flow elements may be hidden to simplify the view and make it easier to view the desired work area. Double clicking on a labeled item opens a dialogue box to make adjustments.

Settings and changes take effect immediately, since the control panels are connected to the processors in real time. All delays, filters, compressors, limiters and ADFE are fully enabled on all channels at all times.

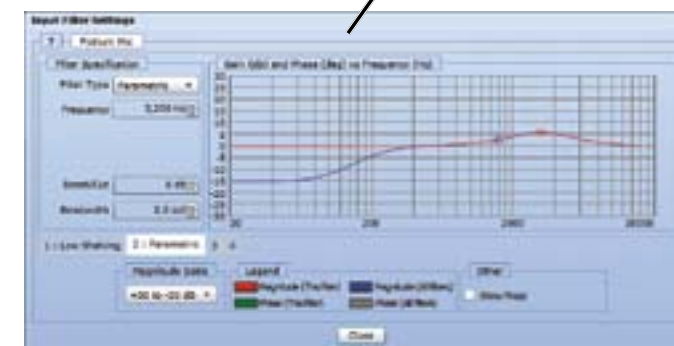
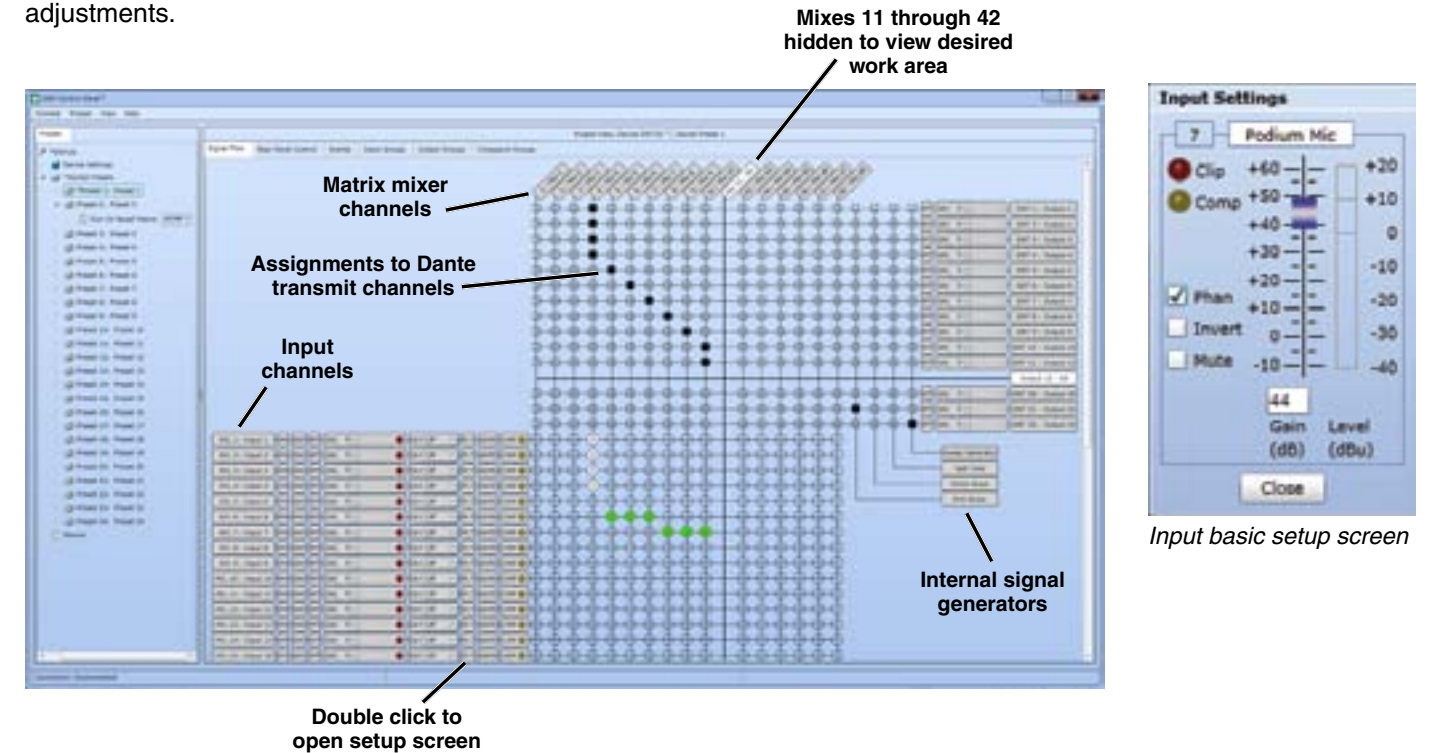

Audinate Dante Controller Software

This is a separate program published by Audinate, the creators of Dante, that is used to define the signal routing in the Dante network. A simple arrangement of columns and rows is used to make transmit and receive channel assignments.

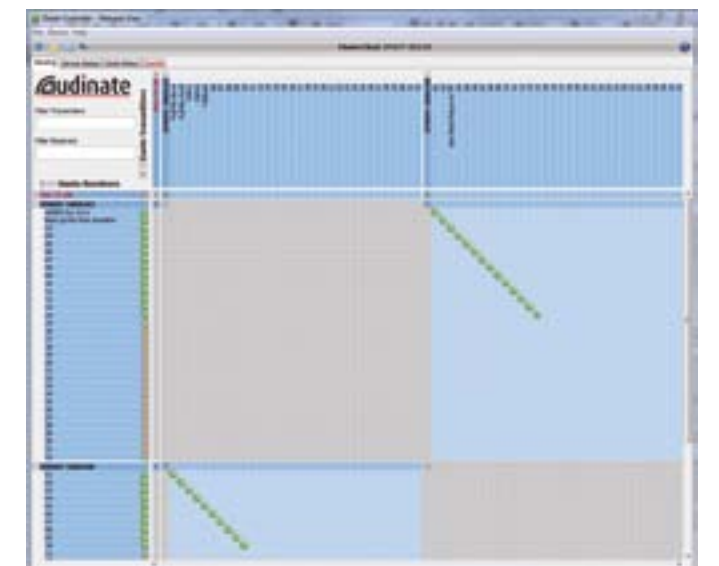

Dante Controller screen used to assign transmit and receive channels

Rear Panel

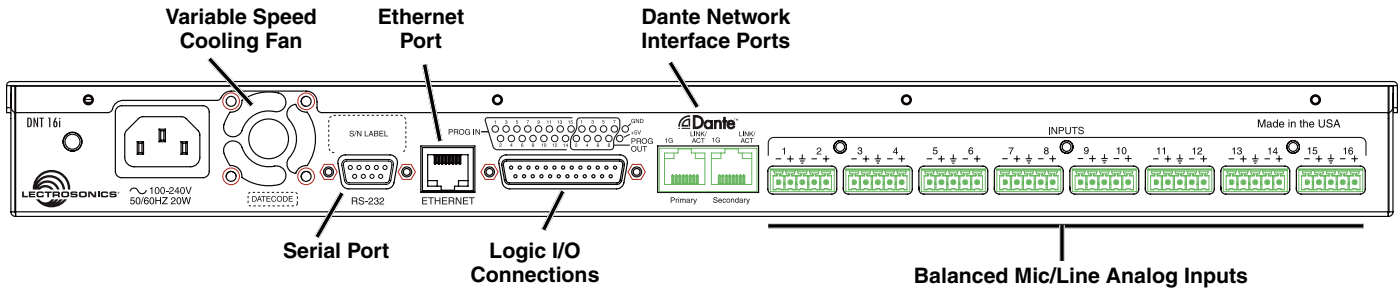

Specifications

Audio inputs:

Balanced mic/line level inputs with digitally programmable gain may be wired as unbalanced inputs.

Audio input channels:	32 total; 16 analog mic/line; 16 Dante digital
Max. input level:	20 dBu
Gain:	Analog: 0 dB to 56 dB, programmable in 8 dB steps (the analog gain is automatically set by selecting the input gain) Digital [Dante]: -70 dB to +20 dB
Input impedance:	8 k Ω differential mode, 2 k Ω common mode
Phantom voltage:	48 V
Dynamic range:	102 dB
EIN:	-127 dBu (20 Hz – 20 kHz, unweighted)
THD + noise:	0.01%
A-D Sampling Rate:	48 kHz; fixed

Audio outputs:

Channels: 32 digital outputs delivered to the Dante network

Dante Interface:

The interface provides dual RJ-45 connectors on the rear panel and an Ethernet switch built into the processor.

Supported sampling rate:	48 kHz
Data rate LED:	100Mbps/1Gbps blinks when active
Activity LED:	
Modes of operation:	Switched mode using either connector Redundant mode with primary and secondary networks using both connectors

Network Connectivity: Dante interface and Ethernet control can be connected to the same network

Latency:

Component	Audio Samples	Milliseconds
A-D Converter	23	0.47917
ADC-to-DSP	4	0.08333
Dante-to-DSP	4	0.08333
DSP	1	0.02083
DSP-to-DAC	4	0.08333
DSP-to-Dante	4	0.08333
Dante-to-Dante		0.15, 0.25, 0.5, 1, 2, 5 as selected

Filters:

All filters have zero processing delay.

Tone control stages:	4 per input channel
ADFE:	8 per input channel; configurable as static or dynamic

Internal Signal Generator:

Swept sine:	Modes: single sweep, continuous sweep Waveforms: sawtooth (up or down), triangle Sweep rate: linear, logarithmic Parameters: start freq, stop freq, level [dBu], sweep time [sec]
White noise parameter:	Level [dBu]
Pink noise parameter:	Level [dBu]
Tone (sine wave) parameters:	Level [dBu], frequency

Filter types:

Low Pass:	Butterworth (6, 12, 18, 24 dB/octave) Bessel (6, 12, 18, 24 dB/octave) Linkwitz-Riley (12, 24 dB/octave) Additional parameters: frequency [Hz]
High Pass:	Butterworth (6, 12, 18, 24 dB/octave) Bessel (6, 12, 18, 24 dB/octave) Linkwitz-Riley (12, 24 dB/octave) Additional parameters: frequency [Hz]
Low Shelving:	Butterworth (6, 12, 18, 24 dB/octave) Bessel (6, 12, 18, 24 dB/octave) Additional parameters: frequency [Hz] boost/cut [dB]
High Shelving:	Butterworth (6, 12, 18, 24 dB/octave) Bessel (6, 12, 18, 24 dB/octave) Additional parameters: frequency [Hz] boost/cut [dB]
Peaking EQ (parametric):	Parameters: frequency [Hz] bandwidth [octave] boost/cut [dB]

Compressor:

Soft knee with RMS level detector eliminates need for separate attack and delay settings; 0.1 ms increments, 1 second max.; continuously adjustable ratio

Power Requirements: 100-240 VAC, 50/60 Hz

Power Consumption: 20 W maximum

Dimensions: 1.75 x 19.00 x 7.70 inches

Weight: 5.32 lbs., 1.7 kg.



581 Laser Road NE • Rio Rancho, NM 87124 USA • www.lectrosonics.com
(505) 892-4501 • (800) 821-1121 • fax (505) 892-6243 • sales@lectrosonics.com